

## Systems Design and Programming

**Instructor:**

Chintan Patel

**Text:**

Barry B. Brey, "The Intel Microprocessors, 8086/8088, 80186/80188, 80286, 80386, 80486, Pentium and Pentium Pro Processor, Pentium II, Pentium III and Pentium 4, Architecture, Programming and Interfacing" Sixth Edition, Prentice Hall (2003).

**Supplementary text:**

Muhammad Ali Mazidi and Janice Gillispie Mazidi, "The 80x86 IBM PC and Compatible Computers (Volumes I&II), Assembly Language, Design, and Interfacing", Third Edition, Prentice Hall (2000).

**Lab Text:**

Bob Neveln, "Linux Assembly Language Programming", Prentice Hall PTR.

**Web:** <http://www.cs.umbc.edu/~cpatel2>

## Course Description

This course covers:

- Intel 80x86 assembly language.
- Architecture of the Intel microprocessors.
- Hardware configuration and control of:
  - Common microprocessor support chips, e.g. Interrupt controller.
  - Popular I/O devices, e.g. UART, sound card.

Prerequisites:

Experience with the C programming language.  
Some familiarity with Operating Systems, such as Windows.  
Experience with the Linux operating system.



## 80x86 Evolution

4004:

- 4-bit microprocessor.
- 4KB main memory.
- 45 instructions.
- PMOS technology.
- 50 KIPS

8008: (1971)

- **8-bit** version of 4004.
- **16KB** main memory.
- 48 instructions.
- NMOS technology.

8080: (1973)

- 8-bit microprocessor.
- **64KB** main memory.
- 2 microseconds clock cycle time; 500,000 instructions/sec.
- 10X faster than 8008.

## 80x86 Evolution

8085: (1977)

- 8-bit microprocessor - upgraded version of the 8080.
- 64KB main memory.
- **1.3 microseconds** clock cycle time; 769,230 instructions/sec.
- 246 instructions.
- Intel sold 100 million copies of this 8-bit microprocessor.

8086: (1978) 8088 (1979)

- **16-bit** microprocessor.
- **1MB** main memory.
- 2.5 MIPS (400 ns).
- 4- or 6-byte instruction cache.
- Other improvements included more registers and additional instructions.

80286: (1983)

- 16-bit microprocessor very similar in instruction set to the 8086.
- **16MB** main memory.
- 4.0 MIPS (250 ns/8MHz).



## 80x86 Evolution

80386: (1986)

- **32-bit** microprocessor.
- **4GB** main memory.
- 12-33MHz.
- Memory management unit added.
- Variations: DX, EX, SL, SLC (cache) and SX.

80386SX: 16MB through a 16-bit data bus and 24 bit address bus.

80486: (1989)

- 32-bit microprocessor, 32-bit data bus and 32-bit address bus.
- 4GB main memory.
- 20-50MHz. Later at 66 and 100MHz
- Incorporated an 80386-like microprocessor, 80387-like floating point coprocessor and an 8K byte cache on one package.
- About half of the instructions executed in 1 clock instead of 2 on the 386.
- Variations: SX, DX2, DX4.

DX2: Double clocked version:

66MHz clock cycle time with memory transfers at 33MHz.

## 80x86 Evolution

Pentium: (1993)

- 32-bit microprocessor, 64-bit data bus and 32-bit address bus.
- 4GB main memory.
- 60, 66, 90MHz.

1-and-1/2 100MHz version.

Double clocked 120 and 133MHz versions.

Fastest version is the 233MHz (3-and-1/2 clocked version).

- **16KB L1 cache (split instruction/data: 8KB each).**
- Memory transfers at **66MHz** (instead of 33MHz).
- **Dual integer processors.**

80486DX

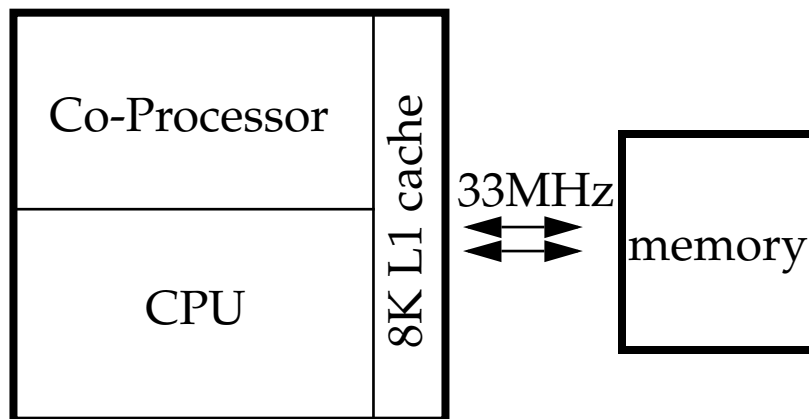

Pentium

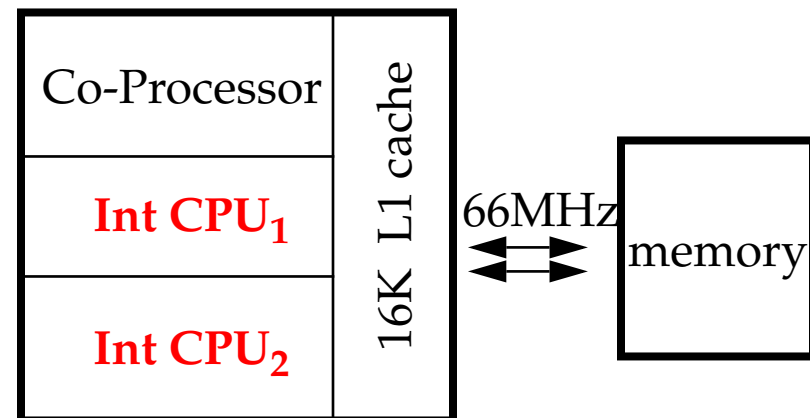

## 80x86 Evolution

Pentium Pro: (1995)

- 32-bit microprocessor, 64-bit data bus and 36-bit address bus.
- **64GB** main memory.
- Starts at 150MHz.
- 16KB L1 cache (split instruction/data: 8KB each).
- **256KB L2 cache.**
- Memory transfers at 66MHz.
- **3 integer processors.**

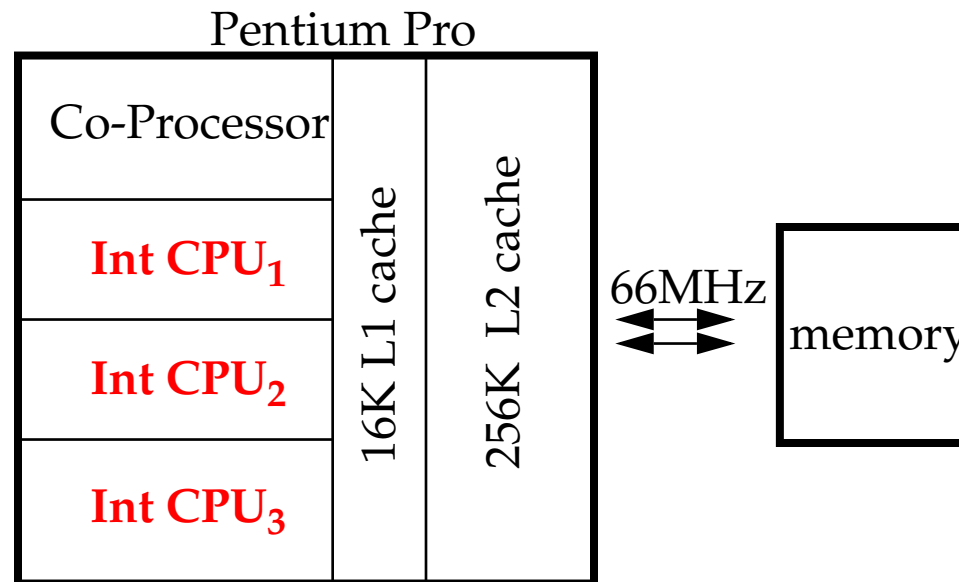

## 80x86 Evolution

Pentium II: (1997)

- 32-bit microprocessor, 64-bit data bus and 36-bit address bus.
- 64GB main memory.
- Starts at 266MHz.
- **32KB** split instruction/data L1 caches (16KB each).
- **Module integrated 512KB L2 cache (133MHz).**
- Memory transfers at 66MHz to **100MHz** (1998).

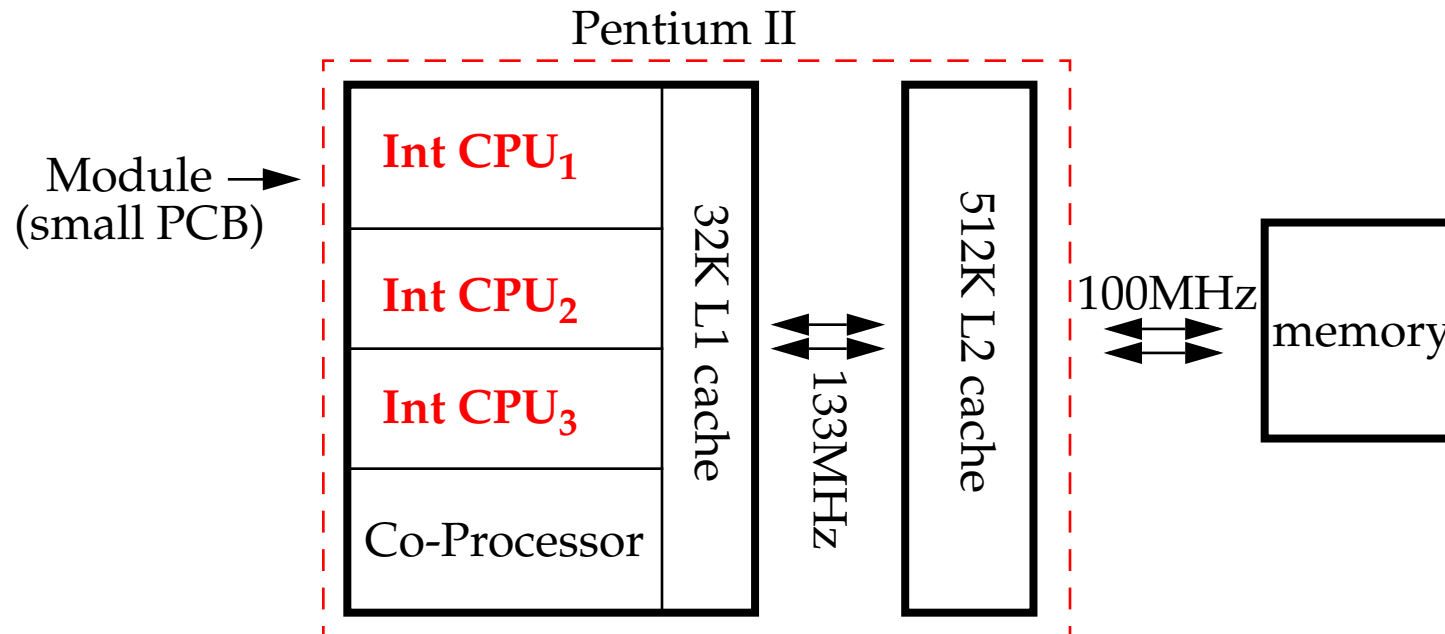



## 80x86 Evolution

Pentium III: (1999)

- 32-bit microprocessor, 64-bit data bus and 36-bit address bus.
- 64GB main memory.
- 800MHz and above.
- 32KB split instruction/data L1 caches (16KB each).
- **On-chip 256KB L2 cache (at-speed).**
- Memory transfers 100MHz to 133MHz.
- **Dual Independent Bus (simultaneous L2 and system memory access).**

Pentium III

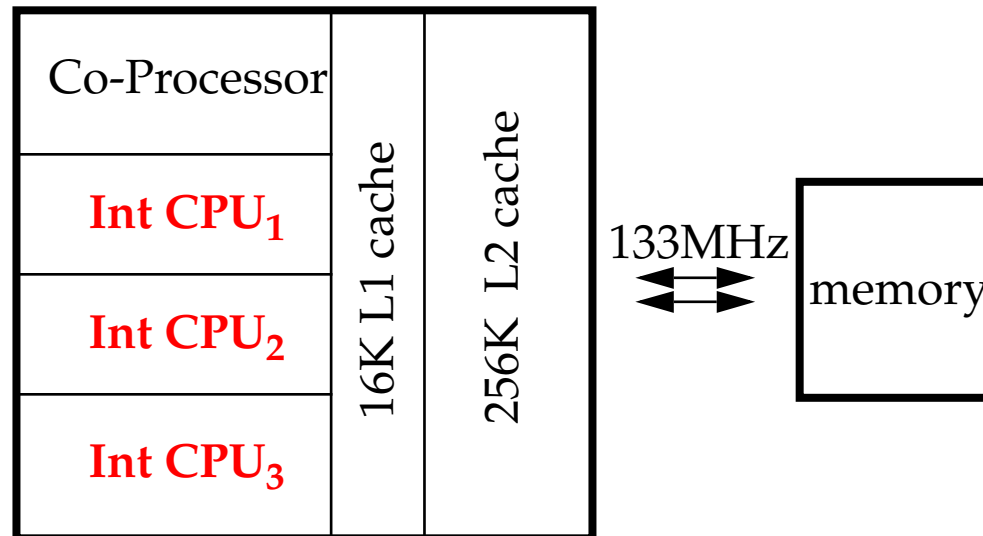

**80x86 Evolution**

Pentium IV: (2002)

- 1.4 to 1.9GHz and the latest at 3.06 GHz and 3.40GHz (Hyper-Threading)!
- 1MB/512KB/256KB L2 cache.
- 800 MHz (about 6.4GB/s)/533 MHz (4.3 GB/s)/ 400MHz (3.2 GB/s) system bus.
- Specialized for streaming video, game and DVD apps (144 new SIMD 128-bit instructions).
- 0.13um, more than 55 million transistors, 60nm transistors.
- Next Generation just around the corner 90nm transistors, 125 million possible.

