

Path Counting

The number of paths can be an exponential function of the # of gates.

Parallel multipliers are notorious for having huge numbers of paths.

It is possible to efficiently count paths in spite of this however.

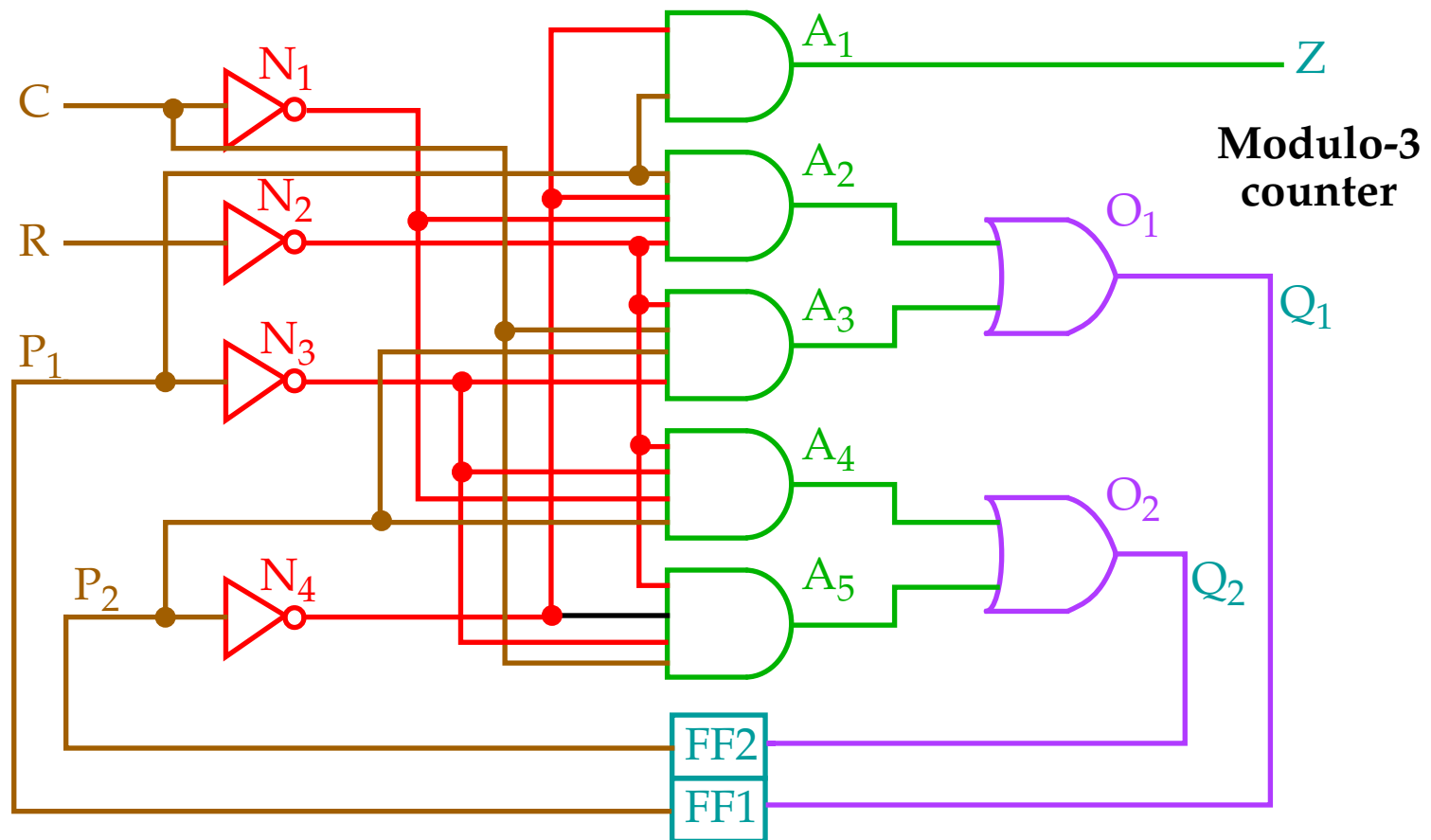

Path Counting

Directed acyclic graph (DAG) path graph for this circuit:

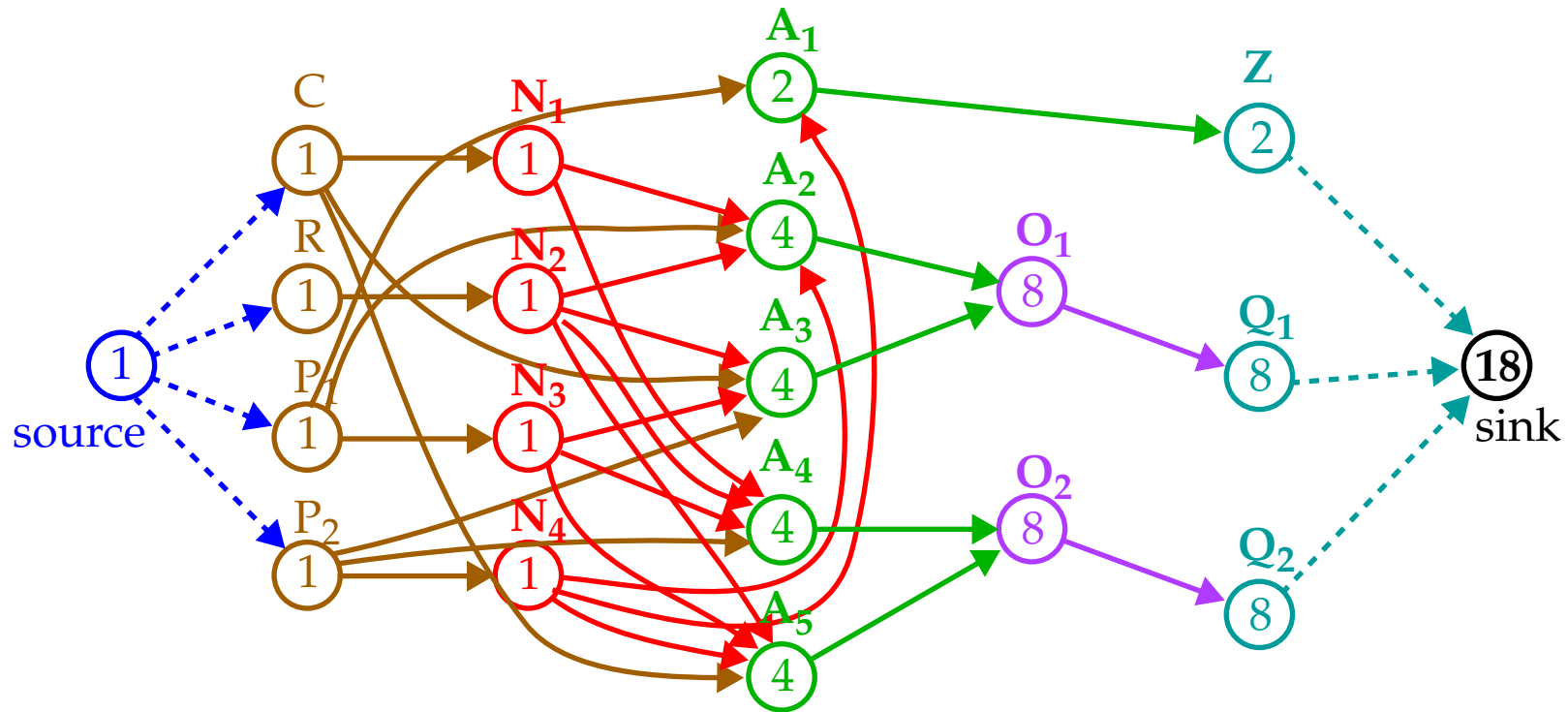

Vertices represent the PIs, POs and gates, edges represent signal flow.

Source and sink nodes are added to point to PIs and POs, algorithm visits each node, follows its edges and adds src value to destination nodes.

Since the maximum *indegree* is $O(N)$, worst case complexity is $O(N^2)$.

Transition Fault Model

Faults are modeled at the gate I/Os as *slow-to-rise* (STR) and *slow-to-fall* (STF) faults that elicit **Stuck-At** type fault behavior at the POs.

For detection of a *slow-to-rise* fault, start with a SA0 fault on the line.

- This sets the line to 1 and propagates the state of the line to a PO.
- Let this be vector V_2 then define V_1 as a vector that sets the line to 0.

Advantages include:

- Number of tests is upper bounded by twice the number of lines.
- Stuck-at ATPG algorithms can be easily modified to produce these tests.

Transition fault tests can detect large (gross) delays.

Tested paths may be short.

They are not reliable at detecting delay defects that are **distributed**, unlike PDF.

Transition fault tests are usually augmented by *critical* path delay tests.

Delay Test Methodologies

The application of delay tests depends on the type of circuit and the DFT hardware used.

- Slow-clock combinational test
- Enhanced-scan test
- Normal-scan sequential test
- Variable-clock non-scan sequential test
- Rated-clock non-scan sequential test

Slow-clock combinational test

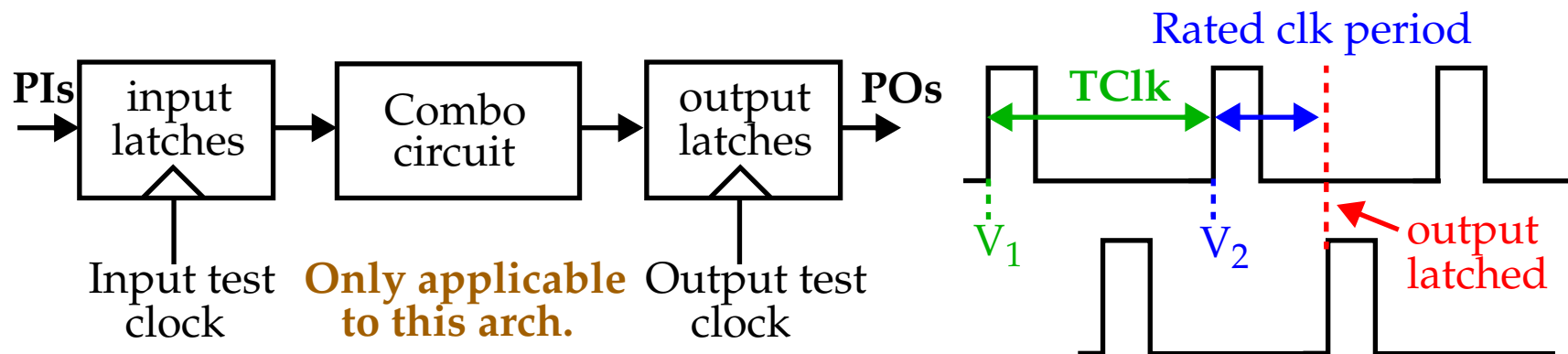

Note that V_1 is applied at a slower rate and the circuit is allowed to stabilize.

Delay Test Methodologies

Enhanced scan test

Applicable to scan types of sequential circuits.

Similar to the previous method, any arbitrary vector pair can be applied and test generation can treat the circuit as combinational.

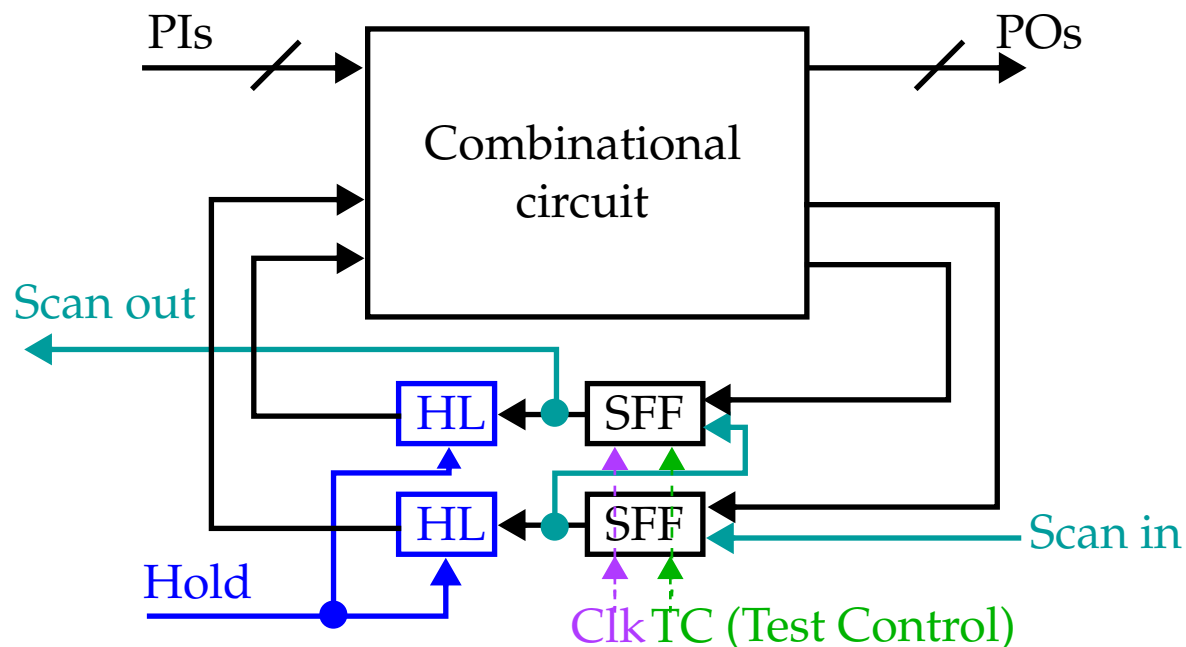

Each vector consists of two parts, bits for the PIs and bits for the state variables (SFFs).

State bits are scanned in by setting TC to 0 and applying Clk.

Delay Test Methodologies

Enhanced scan test (cont.)

The bits are often scanned in using a slow clock to reduce power consumption and the chance of errors occurring due to scan chain delays.

The scanned V_1 bits are transferred to the *Hold Latches* (HL) and the PI bits of V_1 are applied.

When V_1 stabilizes, the state bits of V_2 are scanned in.

Activation of the *Hold* signal and application of the V_2 bits to the PIs creates the $V_1 \rightarrow V_2$ transition.

With $TC = 1$, Clk is used to latch the outputs in *normal mode*.

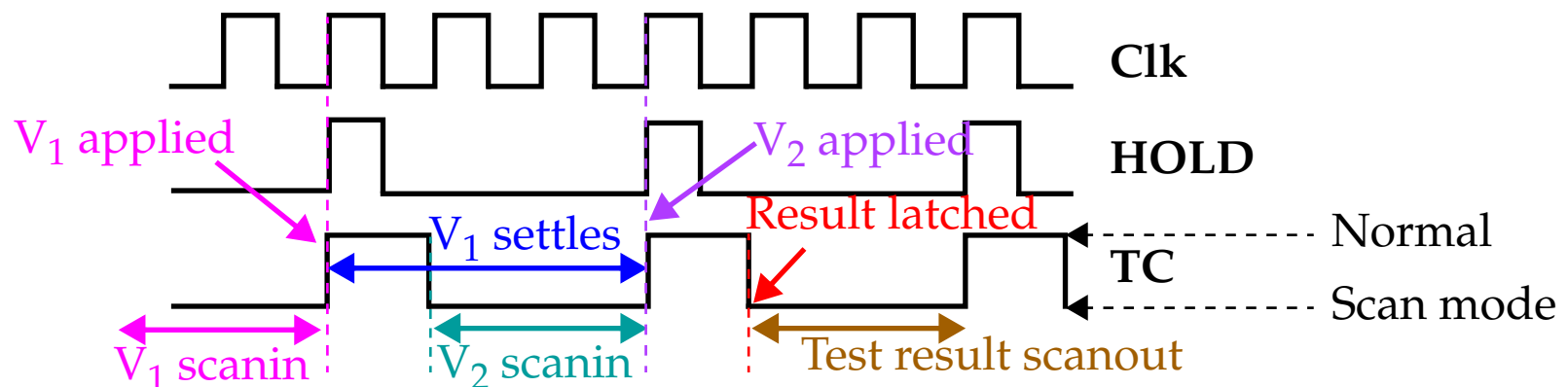

Delay Test Methodologies

Enhanced scan test (cont.)

Scan test time similar to full scan design but scan area overhead is larger and *Hold Latches* increase delay in signal paths.

Normal-scan sequential test

It is still possible to test full scan circuits with no *Hold Latches* for delay faults.

However, it requires special vector-pairs.

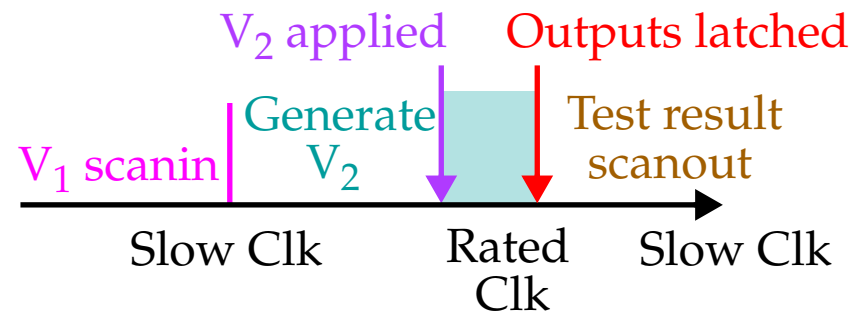
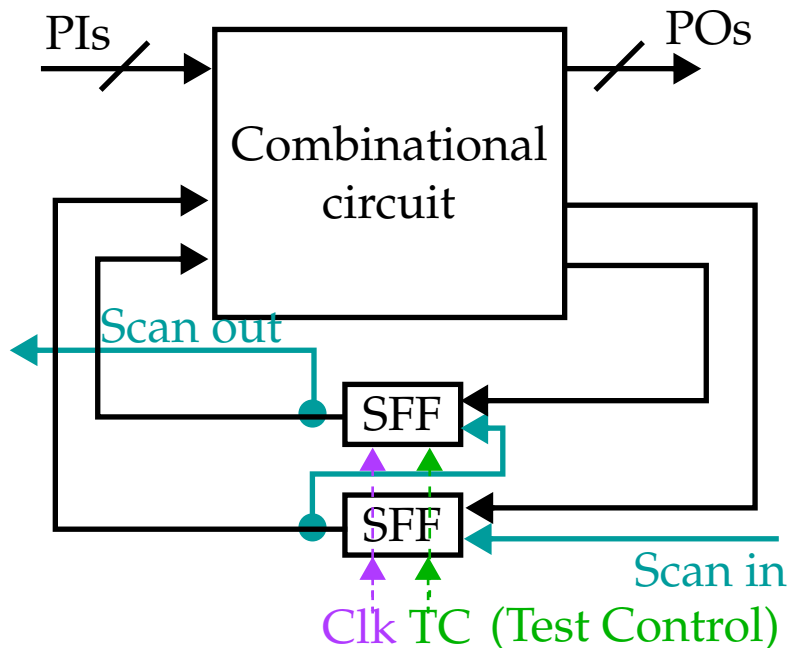

Scan-shift delay test or Skewed-load delay test

Delay Test Methodologies

Normal-scan sequential test

Scan-shift delay test: Scan in of V_1 is followed by one extra cycle of slow clock with the circuit still in scan mode (TC = 0).

The test is designed so that V_2 is obtained from V_1 by a 1 bit translation (PI bits of both vectors are unrestricted).

As soon as V_2 is applied, mode is changed from scan to normal and Clk is controlled at the rated period to latch outputs.

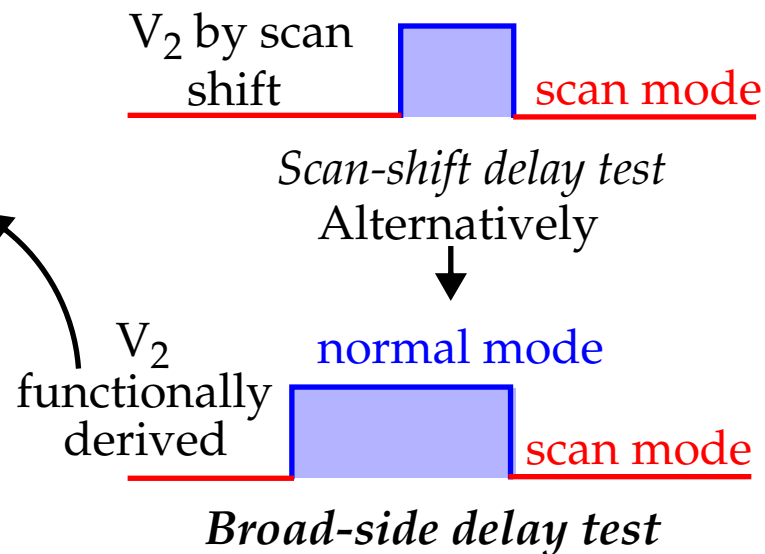
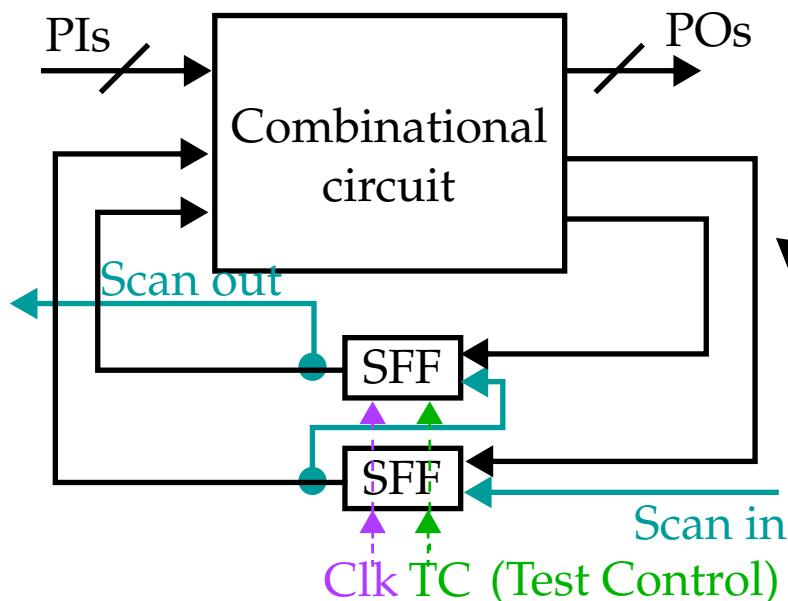

Delay Test Methodologies

Normal-scan sequential test

For *broad-side* delay test, the **state** portion (FF values) of V_2 must be functionally generated by the combinational logic under V_1 .

Simultaneous application of V_2 at the PIs and into the FFs via Clk in normal mode generates the $V_1 \rightarrow V_2$ transitions.

The outputs are latched one rated clock period later.

Correlations between V_1 and V_2 may not allow high fault coverage for path-delay and transition fault tests.

Variable-clock non-scan sequential test

(see text)

Rated-clock non-scan sequential test

(see text)

Practical Considerations in Delay Testing

Today, verification requires both function and timing analysis.

Static timing analysis examines combinational paths without regard to sensitization (delays of gates and wires are looked up in a database).

Results of timing analysis used to improve the design and test:

- *Timing simulation:*

Identified critical paths are simulated and the design is "tweaked" to make sure it meets the timing specification.

- *Critical path tests:*

Critical path delay determines the clock period, and therefore tests are usually included to test such paths.

- *Layout optimization:* Critical path data is used for std. cell/custom block placement, to establish priorities in routing and for transistor sizing.

Practical Considerations in Delay Testing

Critical path tests are good at detecting "correlated defects", i.e., slow-downs due to global process variations, because the longest paths will fail first.

Spot defects (or gross defects) affect only a small number of paths in the chip.

Transition fault tests are capable of detecting these gross delay defects.

Two forms of **at-speed** testing:

- External:

The combination of *critical path* testing and *transition fault* testing provides adequate at-speed testing.

- Built-in self-test:

Since the at-speed ATE is expensive, **BIST** is an alternative.

On-chip hardware is needed for test generation and response analysis.

The speed of BIST is controlled by the off-chip clock.